

## INSTALLATION, OPERATING & MAINTENANCE MANUAL

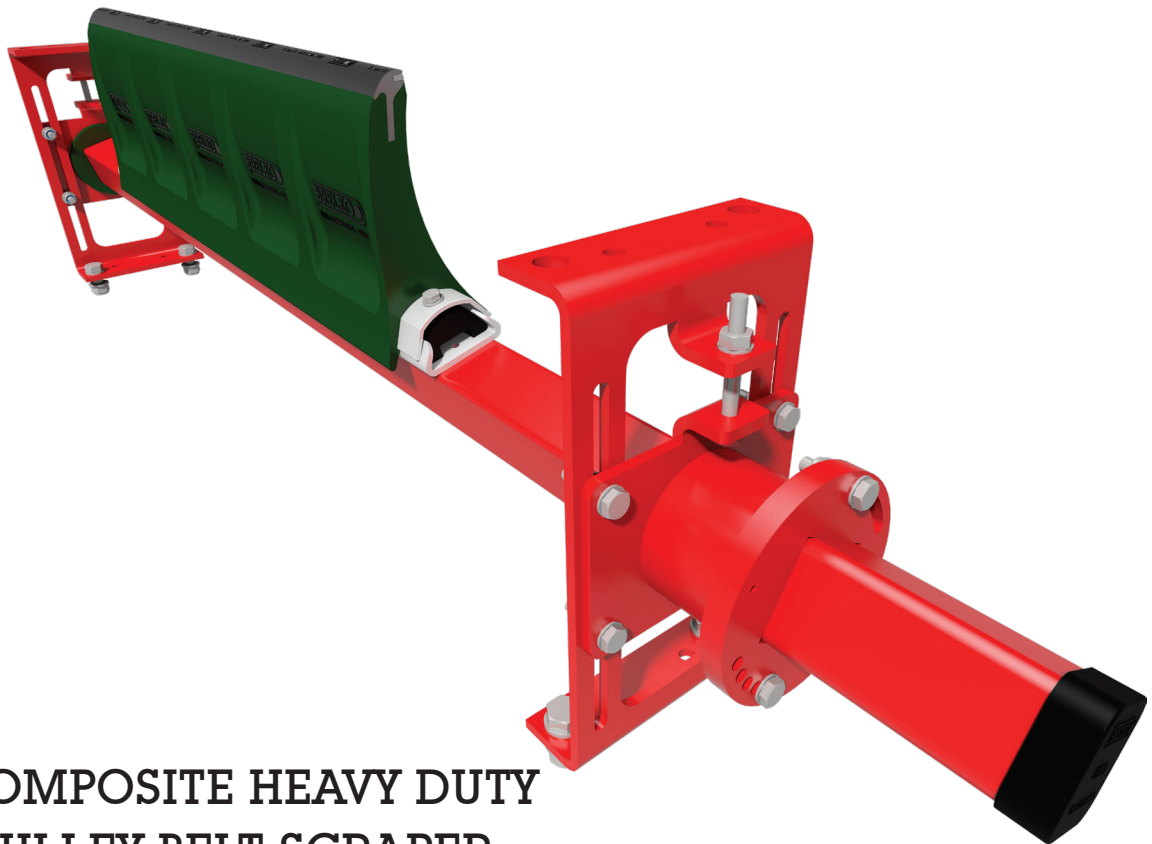

### E951 COMPOSITE HEAVY DUTY HEAD PULLEY BELT SCRAPER

PATENTED

Model Number	:	
Purchase Date	:	
Purchased From	:	
Installation Date	:	

Model number information can be found on the Label found on the scraper carton. This information will be helpful for any future inquiries or questions about belt scraper replacement parts, specifications or troubleshooting.

## Table of Contents

1.	Disclaimer	330
2.	Safety Note	330
3.	The following symbols may be used in this manual:	330
4.	General Information	330
4.1.	Application and Features	331
4.2.	Reference Drawing - E911-001	332
5.	Handling	333
5.1.	Receiving the goods	333
5.2.	Work Safety	333
5.3.	Handling	334
5.4.	Storage	334
5.5.	Preparations for installing Belt Scrapers	334
5.6.	Recommended Tools List	334
6.	Maintenance	335
6.1.	New Installation	335
6.2.	Routine Visual Inspection (every 2~4 weeks)	335
6.3.	Routine Physical Inspection (every 6~8 weeks)	335
6.4.	Parts List and Assembly Instructions	336
6.5.	Reference Drawing - E911-002	337
6.6.	Installation Instructions	338
6.7.	Reference Drawing - E911-003	339
7.	Procedure for Replacing/Repairing Scrapers	340
8.	Maintenance Log	341
9.	Conveyor Belt & Equipment Check List	342
10.	Trouble Shooting	345

## 1. Disclaimer

Brelko conveyor products (pty) ltd hereby disclaims any liability for: damage due to contamination of the material; user's failure to inspect, maintain and take reasonable care of the equipment; injuries or damage resulting from use or application of this product contrary to instructions and specifications contained herein. Brelko's liability shall be limited to repair or replacement of equipment shown to be defective.

## 2. Safety Note

Observe all safety rules given herein along with owner and Government standards and regulations. Know and understand lockout/tag-out procedures as defined by National Standards Institutes, National Standard for Personnel Protection - Lockout/Tag-out of Energy Sources - Minimum Safety Requirements and Occupational Health and Safety.

## 3. The following symbols may be used in this manual:



**Danger:** Immediate hazards that will result in severe personal injury or death.



**Warning:** Hazards or unsafe practices that could result in personal injury.



**Caution:** Hazards or unsafe practices that could result in product or property damages.

**Important:**

**Important:** Instructions that must be followed to ensure proper installation/operation of equipment.

**Note:**

**Note:** General statements to assist the reader.

## 4. General Information

Brelko belt scrapers are designed to operate with minimum maintenance. However, to maintain superior performance some service is required. When the scraper is installed a regular maintenance program should be set up. This program will ensure that the scraper operates at optimal efficiency and problems can be identified and fixed before the scraper stops working. All safety procedures for inspection of equipment (stationary or operating) must be observed. Secondary Scrapers operates at the discharge end of the conveyor and is in direct contact with the moving belt. Only visual observations can be made while the belt is running. Service tasks can be done only with the conveyor stopped and by observing the correct lockout/tag-out procedures.

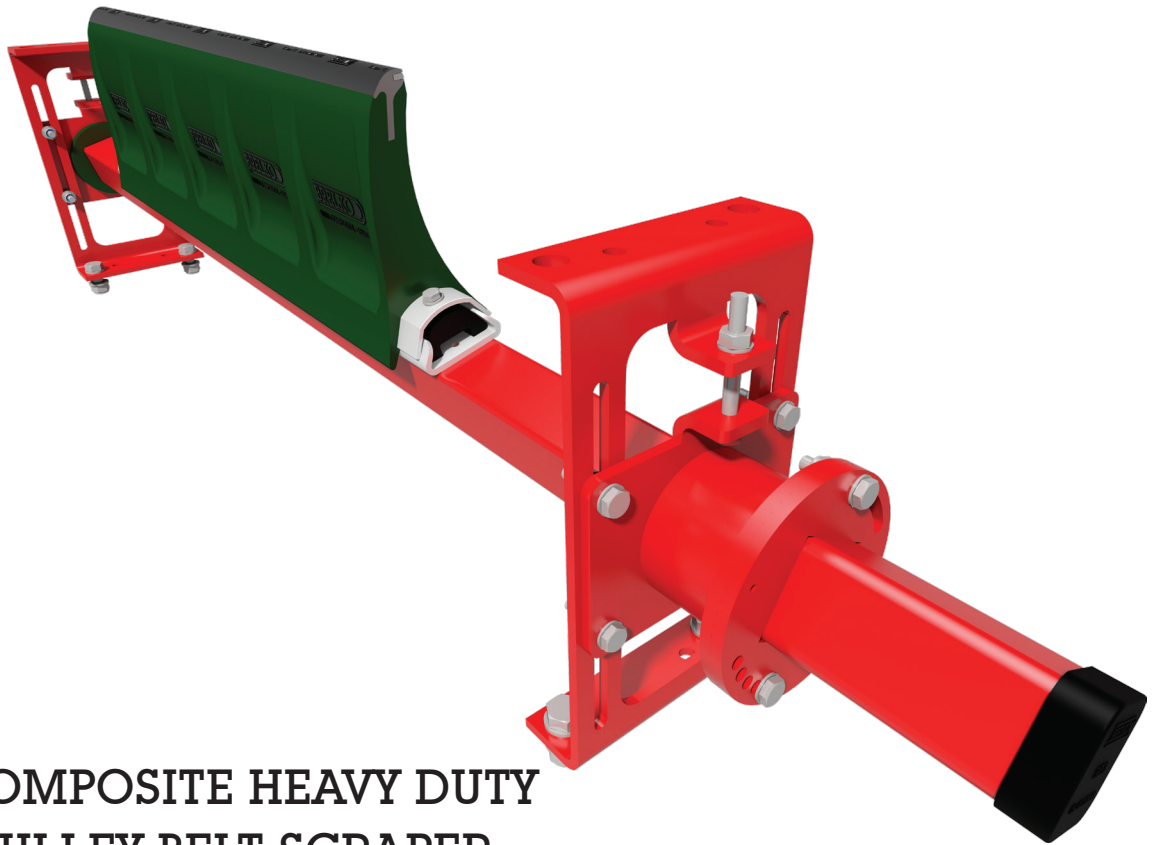

## E951 COMPOSITE HEAVY DUTY HEAD PULLEY BELT SCRAPER

PATENTED

### APPLICATIONS

- As a Heavy Duty Head Pulley Scraper, working directly on the head pulley.
- Can be used on high speed and steel cord belts.
- Low impact small particle size materials only.
- Suitable for all types of conveyor belts with vulcanized joints.
- Suitable for use in corrosive conditions.
- Used in conjunction with Brelko Secondary Scrapers.

### FEATURES

- Ceramic or Tungsten blade holders with Boron Carbide (BC) and Tungsten Carbide (T3) inserts for long life.
- Compact torsion twist tensioners for easy adjustment.
- Chute side mountings for easy adjustment and installation.
- Low friction and heat generation.
- Robust construction for longer life.
- Patented V-base blade mounting makes blade changing quick and simple.
- Specially formulated composite blades give maximum life, and ensure accurate assembly and a clean running scraper.
- Streamlined scraper construction prevents material build-up on the scraper.

# E951-TT TWIST TENSIONER MOUNT SINGLE ROW MULTI-BLADE HEAD PULLEY SCRAPER

© 07-2015

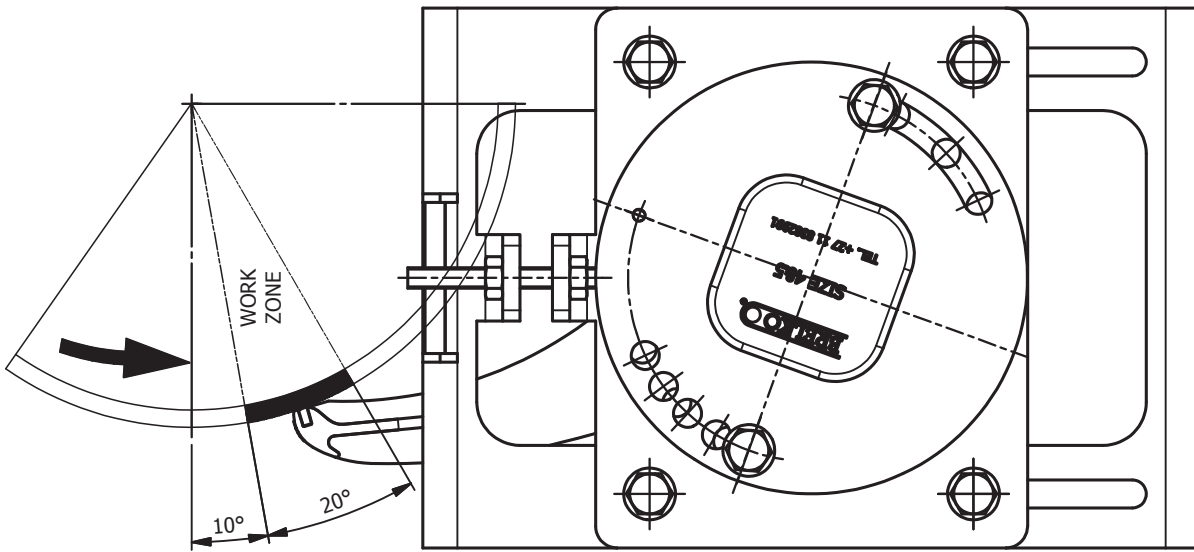

E951-TT  
TWIST TENSIONER MOUNTING

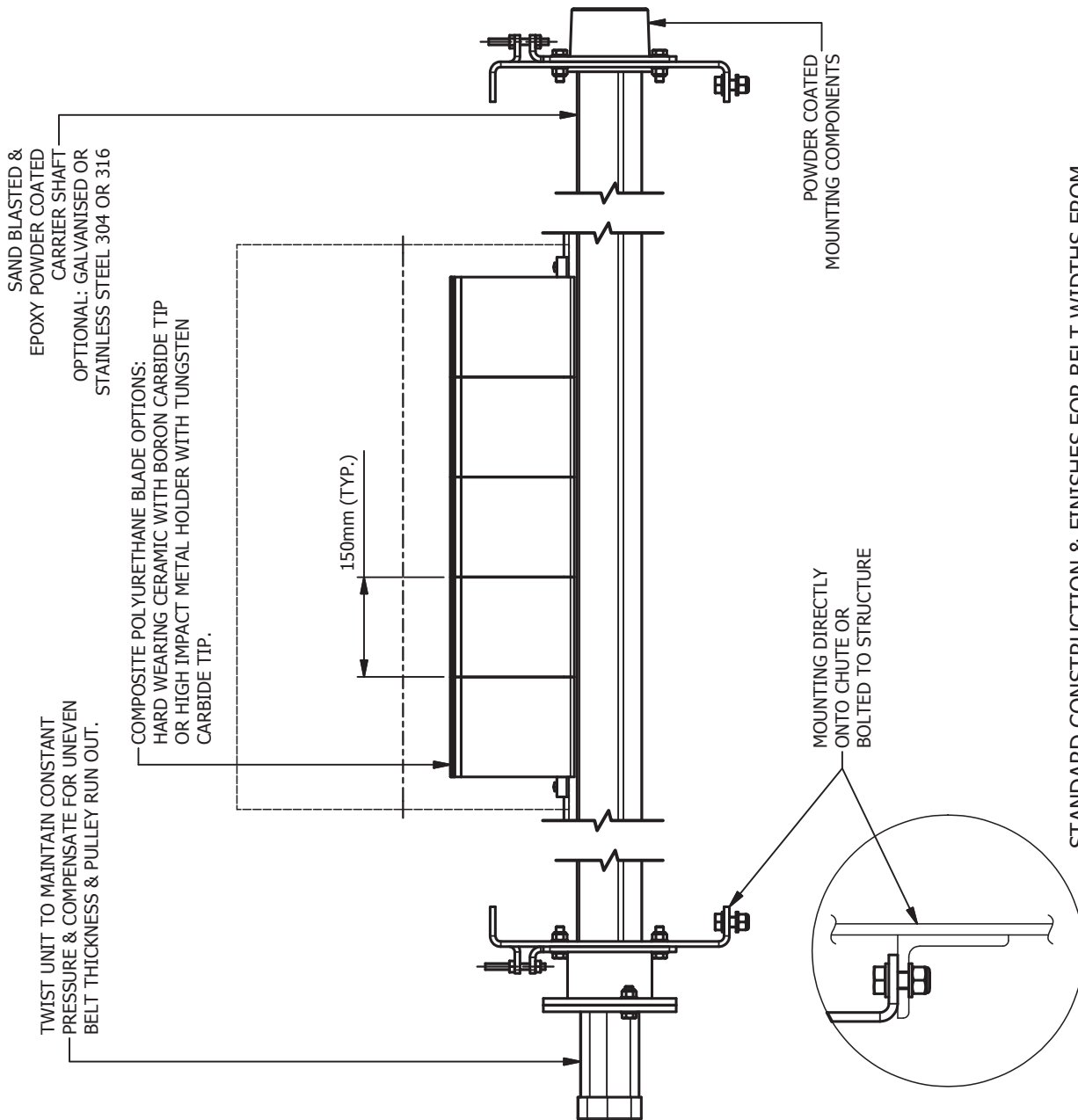

STANDARD CONSTRUCTION & FINISHES FOR BELT WIDTHS FROM  
600mm TO 2100mm

NOTE: FEATURES & OPTIONS SHOWN:  
PLEASE REFER TO DETAILED MANUAL FOR INSTALLATION INSTRUCTIONS, MAINTENANCE & SPARE PARTS

DRW: E951-041  
No.

REV. D

## 5. Handling

### 5.1. Receiving the goods

Check that the shipment contains all the products specified in the delivery note. If the goods do not match the delivery note, if the goods show any transportation damage, **list it on the freight bill**. Describe the damage and the number of wrong or faulty goods, **and contact your supplier immediately**.

**Do not use defective parts under any circumstances.** Claims must be made within 8 days from the arrival of goods. The factory does not cover expenses caused by exchange of product when installation was not carried out according to factory instructions.

### 5.2. Work Safety

Always use protective gloves and clothing. Always use a lifeline and soft-sole footwear when work will be carried out on raised platforms. Before you move a scraper or plough, check that it is securely attached to the lifting equipment. Always observe local safety regulations.



Before removing/installing equipment, lock out/tag out energy source to conveyor, and/or conveyor accessories.

Turn off and lock out/tag out energy source according to local standards.

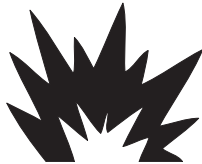

If equipment will be installed in an enclosed area, test gas level or duct content before using a cutting torch or welding. Using a cutting torch or welding in an area with gas or dust may cause an explosion.

If using a cutting torch or welding machine, test atmosphere for gas level or dust content.

### 5.3. Handling

When scrapers are unloaded from the transportation vehicle onto customer's platform, place them on boards spaced max 1m apart at a minimum of 5cm from the ground.

### 5.4. Storage

Scrapers can be stored unpacked or in transportation package. Scrapers must not be stored on top of one another, protect the scrapers by storing them in a cool dry area on a flat surface.

### 5.5. Preparations for installing Belt Scrapers

Before installation, check all measurements and any of the other geometric design

### 5.6. Recommended Tools List

BELT SCRAPERS	
QTY	DESCRIPTION
2	EXTENSION CORD (20m MINIMUM)
1	PORT-A-PACK (OXY-ACETYLENE)
1	PRICKER
1	COMBINATION GAUGE (WITH SPIRIT LEVEL)
1	STRAIGHT EDGE (1M MINIMUM)
1	90° SET SQUARE
1	5M TAPE MEASURE
2	ADJUSTABLE SPANNERS
1	PIPE WRENCH (3" MINIMUM)
1	SOCKET RATCHET SET (6mm - 30mm)
2	RINGSET SPANNERS - M13, 15, 16, 17, 18, 19, 24
1	STANLEY KNIFE
2	M46 SET SPANNERS
2	M65 SET SPANNERS
1	HARD FACE HAMMER – 4pd
1	SOFT FACE HAMMER - 1KG
3M	NYLON ROPE
2	"G" CLAMPS - 6" - 8"
1	JIMMY LEVER

## 6. Maintenance

Brelko belt scrapers are designed to operate with minimum maintenance. However, to maintain superior performance some service is required. When the scraper is installed a regular maintenance program should be set up. This program will ensure that the scraper operates at optimal efficiency and problems can be identified and fixed before the scraper stops working. All safety procedures for inspection of equipment (stationary or operating) must be observed. The E951 Head Pulley Scraper operates at the discharge end of the conveyor and is in direct contact with the moving belt. Only visual observations can be made while the belt is running. Service tasks can be done only with the conveyor stopped and by observing the correct lockout/tag-out procedures.

### 6.1. New Installation

After the new scraper has run for a few days a visual inspection should be made to ensure the scraper is performing properly. Make adjustments as needed.

### 6.2. Routine Visual Inspection (every 2~4 weeks)

- A visual inspection of the scraper and belt can determine:
- If the mounts are adjusted at the correct pressure for optimal cleaning
- If the belt looks clean or if there are areas that are dirty
- If the blade is worn out and needs to be replaced
- If there is damage to the blade or other scraper components
- If fugitive material is built up on the scraper or in the transfer area
- If there is cover damage to the belt
- If there is vibration or bouncing of the scraper on the belt
- If a snub pulley is used, a check should be made for material build-up on the pulley
- If any of the above conditions exist, a decision should be made on when the conveyor can be stopped for scraper maintenance.

### 6.3. Routine Physical Inspection (every 6~8 weeks)

When the conveyor is not in operation and properly locked and tagged out a physical inspection of the scraper to perform the following tasks:

- Clean material build-up off of the scraper blade and pole.
- Closely inspect the blade for wear and any damage. Replace if needed.
- Check blade for proper installation and condition. Replace if needed.
- Ensure full blade to belt contact.
- Inspect the scraper pole for damage.
- Inspect all fasteners for tightness and wear. Tighten or replace as needed.
- Replace any worn or damaged components.
- Check the pressure of the scraper blade on the belt. Adjust the pressure if necessary, refer to scraper model installation guide.

When maintenance tasks are completed, test run the conveyor to ensure the scraper is performing properly.

## PARTS LIST - REF. DRW. No.: E951-043

ITEM No.	DESCRIPTION	SIZE	SHAFT LENGTH (mm)	BELT WIDTH (mm)	PART No.
A.	Carrier Assembly Including shaft, "V" track and end stops.	Size 2	1500	600-750	2/8.1.2
		Size 3	2000	900-1200	2/8.1.3
		Size 4	2500	1350-1500	2/8.1.4
		Size 4	3000	1650-1800	2/8.1.41
B.	Torsion twist Tensioner and mount assembly including bearing, bushes, mounting brackets and tensioner units (Belt Widths 1500 to 2400 require 2 Twist Tensioner Units)	Size 2	N/A	400-750	2/2.33
		Size 3	N/A	900-1200	2/2.34
		Size 4	N/A	1350-2400	2/2.36
C.	Composite Poly Blades				
	Steel Holder and T3 Tip	150mm	N/A	N/A	2/6.52
	Ceramic Holder and BC Tip	150mm	N/A	N/A	2/6.53
D.	Optional / 3-Piece Shaft Assembly including inner carrier shaft, outer carrier shafts.	Size 2	1500	600-750	2/8.1.2/3P
		Size 3	2000	900-1200	2/8.1.3/3P
		Size 4	2500	1350-1500	2/8.1.4/3P
		Size 4	3000	1650-1800	2/8.1.41/3P
		Size 5	4000	2100-2400	2/8.1.5/3P

***NOTE! Always quote belt width.***

### ASSEMBLY INSTRUCTIONS

1. All scrapers will be wrapped and clearly marked with the model number, scraper blade grade and belt width.
  - Note: - Scrapers will be supplied with all nuts and bolts to complete the assembly and installation.
2. Referring to the parts list check that the correct parts and quantities have been supplied for the model and belt width of scraper ordered.
3. Normally scrapers are supplied with blades (3) and end stops (5) assembled and fixed to the carrier shaft. If this is not the case, assemble as shown using lithium base grease as a lubricant to ease future removal of blades. If necessary, use rubber mallet to tap the blades into the "V" track.
4. Proceed with installation as per installation guide.
  - Note : - Care should be taken when handling the ceramic components.

# E951-TT TWIST TENSIONER MOUNT SINGLE ROW MULTI-BLADE HEAD PULLEY SCRAPER

© 07-2015

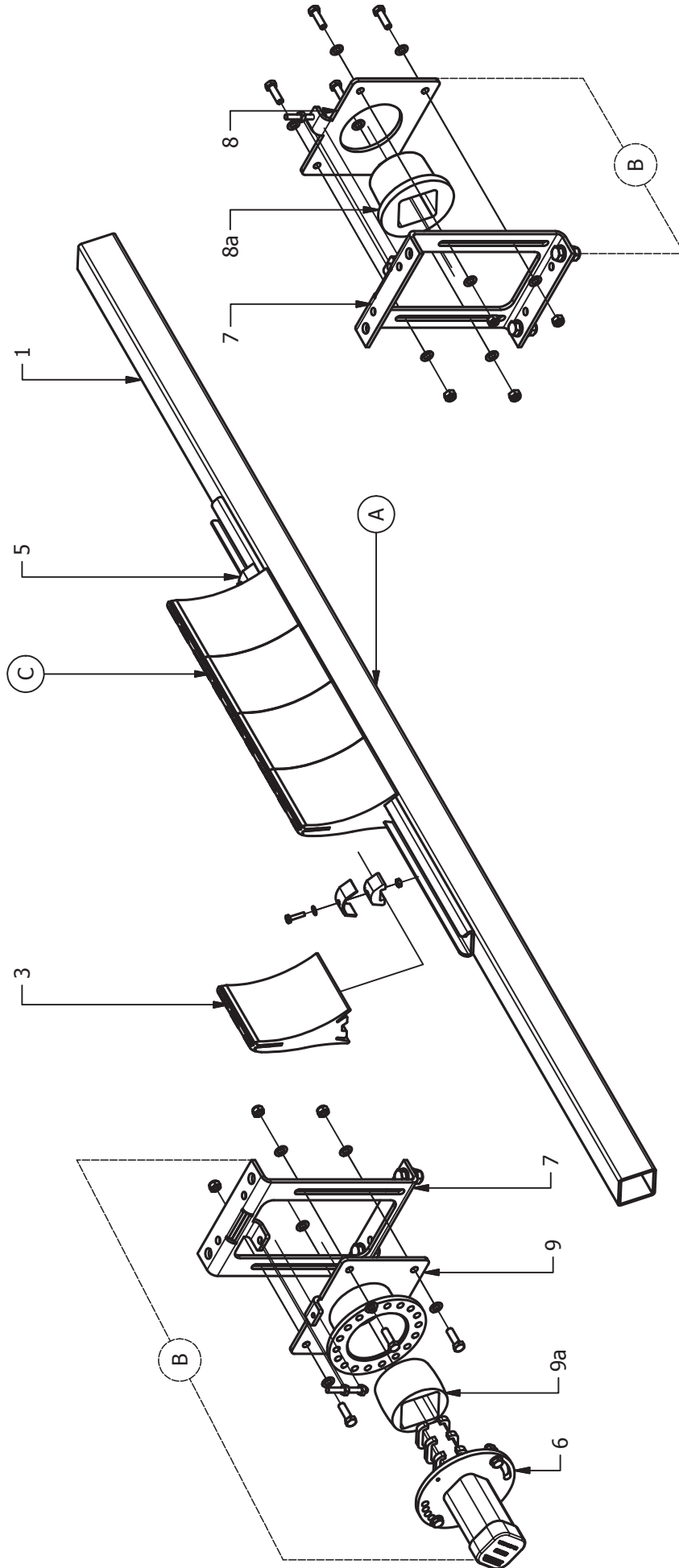

## LEGEND

DESCRIPTION	COMPONENT I.D
CARRIER SHAFT	A
TWIST MOUNT ASSEMBLY (BEARING, BUSHES, MOUNTING BRACKETS & TWIST UNIT)	B
COMPOSITE POLY BLADE (150mm BLADES)	C

PARTS LIST: FOR TWIST TENSIONER MOUNT

PLEASE SPECIFY BELT WIDTH WHEN ORDERING

DRW: E951-043  
No.

REV. D

## INSTALLATION GUIDE - REF. DRW. No.: E951-042

1. Refer to the Assembly Instructions, Parts List and Parts list drawing to confirm that all the necessary parts have been supplied and that the scraper is correctly assembled.
2. Remove mounting brackets (7) from nearside bearing assembly (9) and farside bearing assembly (8).
3. Referring to the installation data sheet and dimensions given in the dimension table determine the scraper work zone and select the optimum position for the scraper.
4. After establishing the optimum position for the scraper on the head pulley, mark and cut out the near and farside chute openings. The farside opening need only accommodate scraper adjustment.
  - Note 1: - Shield the conveyor belt and head pulley to prevent burning during cutting and welding activities.
  - Note 2: - The mounting brackets (7) may be omitted and the bearing plates bolted directly to the chute sides. Separate chute access doors may then be required for inspection and maintenance access. Please consult a Brelko representative for this installation option.
5. With reference to the installation data sheet select the most convenient location for the mounting brackets (7).
  - Note : - Mounting brackets (7) can be welded or bolted to the chute sides.
6. Tack weld the near and farside mounting brackets (7) to the chute sides or bolt to structure.
7. Remove one or both carrier shaft (1) end caps and install scraper through nearside chute opening.
8. Position carrier (1) centrally with reference to belt edges and head pulley and attach the nearside bearing assembly (9) and farside bearing assembly (8) to the mounting brackets (7).
9. Using nearside bearing assembly (9) and farside bearing assembly (8) as reference determine exact carrier (1) length, mark off; remove carrier (1) and nearside bearing assembly (9) and farside bearing assembly (8).
10. Carefully cut carrier shaft (1) to required length and de-burr shaft ends, reposition carrier shaft (1) centrally with reference to belt edges and head pulley.
11. Fit farside bearing bush (8a) over carrier shaft (1) end, and insert carrier shaft (1) end into farside bearing assembly (8). Tighten bolts and nuts, finger tight only as further adjustment of the scraper will be required.
12. Fit nearside bearing bush (9a) over carrier shaft (1) end, and locate nearside bearing assembly (9) as shown. Tighten bolts and nuts, finger tight only as further adjustment of the scraper will be required.
13. Complete welding of near and farside mounting brackets (7) or ensure all mounting brackets (7) nuts and bolts are firmly fastened.
14. Locate tension unit (6) and insert holding bolt into matching holes between the nearside bearing assembly (9). Tighten holding bolt and nut, finger tight only as further adjustment of the scraper will be required.
15. With reference to the dimension data sheet move scraper into the correct scraping position. Tighten bolts and nuts; do not over tighten nuts and bolts as further adjustment of the scraper might be required.
16. Using large tool, turn tension unit to bias scraper against head pulley and insert holding bolt. The tensioner only needs to be rotated until the first set of holding bolt holes between nearside bearing assemblies (9) align.
17. Firmly tighten all nuts and bolts.
18. Start the conveyor and check if all blades are in full contact with the belt surface. If further adjustment is required stop the conveyor and adjust the scraper until the next set of holding bolt holes between nearside bearing assemblies (9) align or until optimum cleaning is achieved.

# E951-TT TWIST TORSION MOUNT SINGLE ROW MULTI-BLADE HEAD PULLEY SCRAPER

© 07-2015

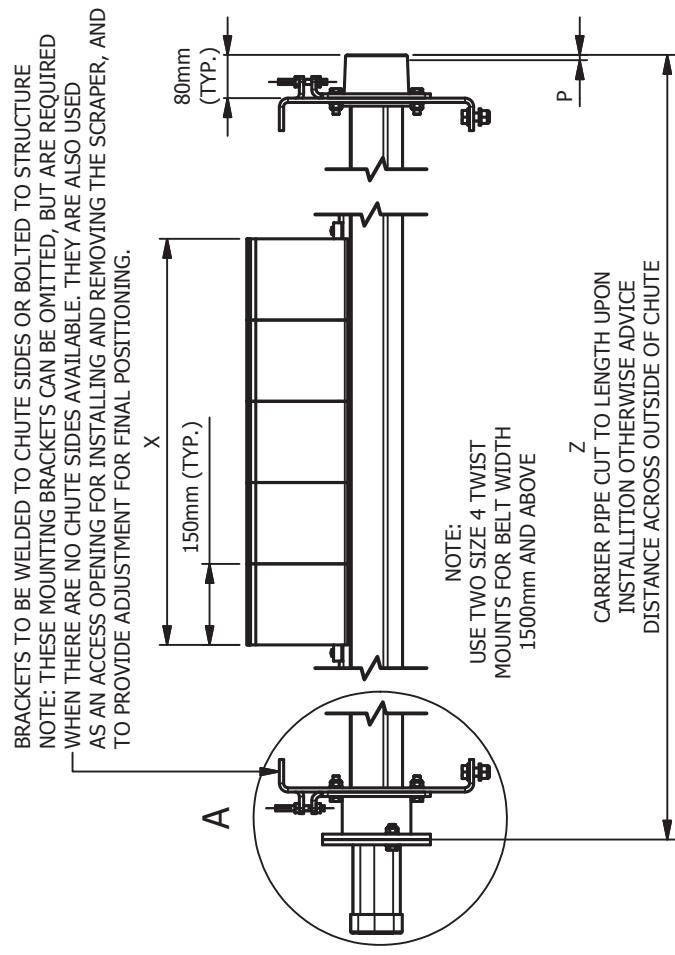
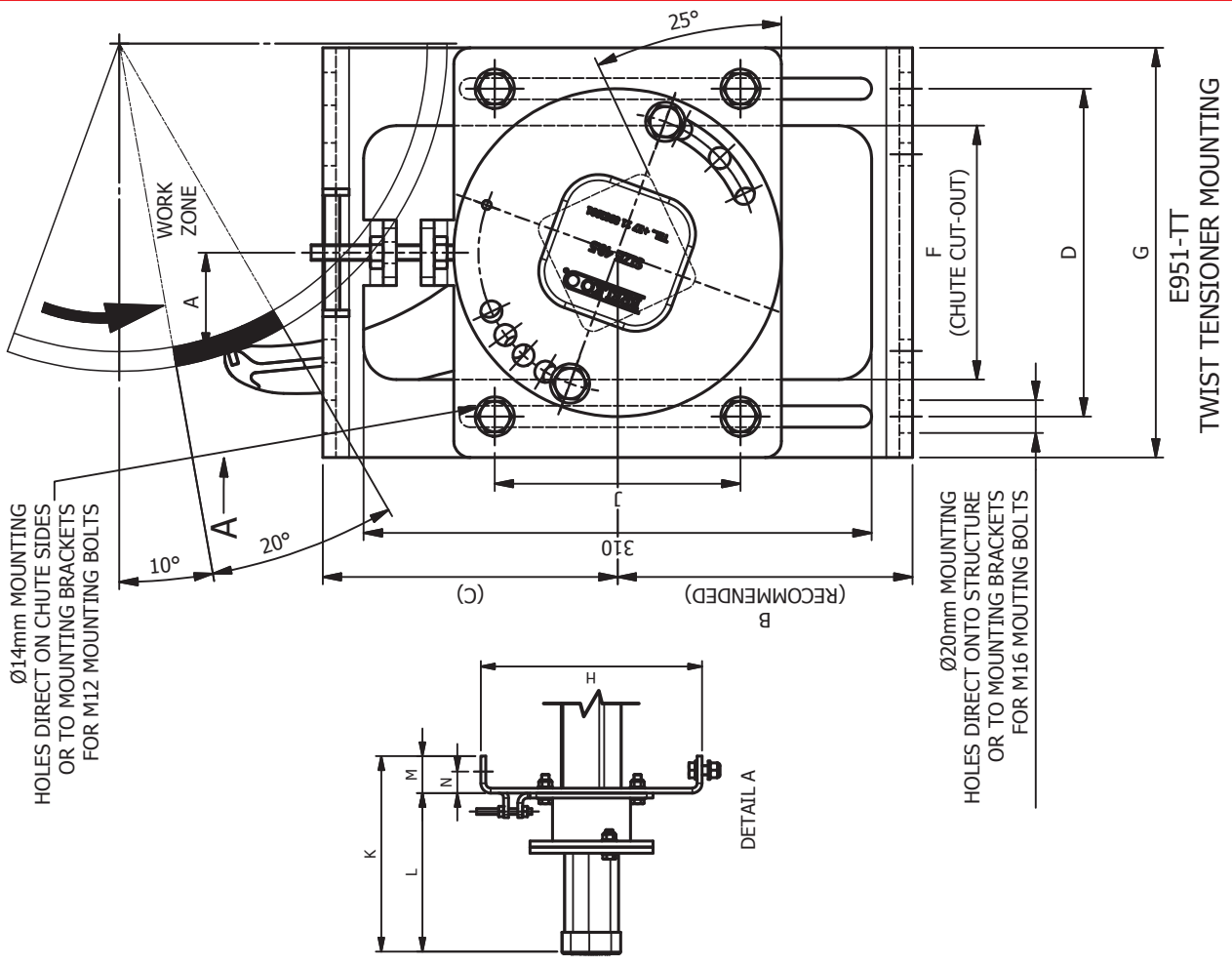

DIMENSION TABLE (mm)		600	750	900	1050	1200	1350	1500	1650	1800	2100	2400
BELT WIDTH		600	750	900	1050	1200	1350	1500	1650	1800	2100	2400
No. BLADES		3	4	5	5	6	7	7	8	9	11	13
SIZE RANGE		2	3	3	4	4	4	4	4	5	5	5
A		53	61	61	61	61	61	61	61	61	61	61
B		145	145	145	155	155	155	155	155	155	155	155
C		205	205	205	205	205	205	205	205	205	205	205
D		150	150	150	150	200	200	200	200	200	200	200
E		280	280	280	280	295	295	295	295	295	295	295
F		115	115	115	115	155	155	155	155	155	155	155
G		190	190	190	190	250	250	250	250	250	250	250
H		350	350	350	350	350	350	360	360	360	360	360
J		100	100	100	100	100	100	150	150	150	150	150
K		300	300	300	300	310	310	310	310	310	310	310
L		240	240	240	240	240	240	250	250	250	250	250
M		60	60	60	60	60	60	60	60	60	60	60
N		20	20	20	20	25	25	25	25	25	25	25
P		5	5	5	5	10	10	10	10	10	10	10
Z		1500	2000	2000	2000	2500	2500	3000	3000	3000	4000 (3 PIECE)	4000 (3 PIECE)
X		450	600	750	750	900	1050	1050	1200	1350	1650	1950

INSTALLATION DETAIL: FOR TWIST TENSIONER MOUNT

DRW. E951-042 No. REV. D

## 7. Procedure for Replacing/Repairing Scrapers

Repair/replace Belt Scraper components when, general maintenance tasks are performed scraper damage due to accelerated blade wear, scraper damage due to blocked chutes, clip joints/emergency belt repairs etc.

- 7.1. Request permit to work from an authorised person, who will isolate and lock out the belt.
- 7.2. Open access door, if provided, and clear loose items about the spindle before commencing with work.
- 7.3. Loosen the locknuts and then lower/raise the scrapers, as necessary.
- 7.4. If replacing scrapers, insert balance pipe – which must be longer than the carrier shaft – into the one end of the shaft.
- 7.5. Loosen the shaft and turn it 180 degrees, that is, scraper tips pointing downward.
- 7.6. Remove one spindle on the intended exit end.
- 7.7. Slide out the scraper assembly from the intended exit end of the pipe.
- 7.8. Service the scraper on the platform.
- 7.9. Blade replacement:

**Refer to Brelko installation instructions for belt scraper model in use.**

Brelko nylon torsion holders have been designed to break out of the torsion holder support v-track to protect the scraper, scraper mounting components, conveyor belt and conveyor belt equipment against damage due to emergency clip joints, loose/damaged splicing, belt protrusions, chute blockages etc. If torsion holders damaged occur follow the steps below to replace individual or all of the torsion holders:

- a. Remove and clean the damaged scraper to assess the amount of damage to the scraper, the scraper torsion holders and scraper components.
  - b. If the scraper has been working for more than 4 weeks and/or there has been significant blade wear remove and replace all the torsion holders and blades and replace with new kits, this will eliminate belt damage due to uneven scraper torsion holder and blades.
  - c. If the scraper has been working for 1~2 weeks replace only damaged torsion holders and blades, however assess the damage and ensure the remaining torsion holders will not cause any damage to the conveyor belt.
- 7.10. Scraper Adjustment:
- Refer to Brelko installation instructions for belt scraper model in use.**
- a. Reposition using the balance pipe.
  - b. Obtain sanction for test, or permission to adjust for performance evaluation.
  - c. Tighten all nuts and ensure that belt cleaning or scraper performance is acceptable.
  - d. Clear up any loose items which resulted from your work.

CUSTOMER: \_\_\_\_\_

CODE:    -

No: 25853

ATTENTION: \_\_\_\_\_ CONTACT TEL: \_\_\_\_\_

CONTRACT/ORDER No.: \_\_\_\_\_ DATE IN: \_\_\_\_\_

### JOB CARD SERVICE WAYBILL

BELT No.	BELT SIZE	EQUIPMENT TYPE	MOUNT TYPE	EQUIPMENT CONDITION (AVERAGE / GOOD / EXCELLENT)	INSPECTION FINDINGS			WORK DONE or ACTION RECOMMENDED						IMPORTANT NOTES / COMMENTS				
					BELT SCRAPER / PRODUCT	CONVEYOR BELT and CHUTE	BUILD-UP	SPARES FITTED <small>Mine Spares = M / Breiko Spares = B</small>	BLADES / HOLDERS	CARRIER ASSEMBLY	SPINDLES	SKIRTING	OTHER SPARES		ADJUST SCRAPER SET	TIGHTEN LOOSE NUTS & BOLTS	FURTHER INVESTIGATION	CLEANED
				PRODUCT LIFE REMAINING (LOW / MEDIUM / HIGH)	NEW / EVEN	GROOVES / WORN	PROTRUSIONS <small>(CLIPS / SPICES / LOOSE FRICH)</small>	EXCESSIVE	AVERAGE	LITTLE								

ALWAYS REFER THE ABOVE COMMENTS TELEPHONICALLY TO THE RELEVANT PERSON FOR SPELLING REFER TO THE GENERAL AND CONVEYING TERMS SHEET INCLUDED IN THE INDEX SECTION OF THIS WAYBILL BOOK.

CUSTOMER REPRESENTATIVE : \_\_\_\_\_ TIME IN: \_\_\_\_\_

(please print)

CUSTOMERS SIGNATURE : \_\_\_\_\_ TIME OUT: \_\_\_\_\_

BRELKO REPRESENTATIVE : \_\_\_\_\_

SAFETY : \_\_\_\_\_



DOC NO.	ISSUE NO.	REVISION	NOVEMBER	PAGE
PS 007	8	8	2011	1 of 2

©2003-05

## CONVEYOR BELT & EQUIPMENT CHECK LIST

### CUSTOMER DETAILS

Customer Name:		Contact Number:	
Attention:		Date of Inspection	
Inspected By		Brelko Representative	

### CONVEYOR DIMENSIONS

Belt Number:		Material Carried:		Belt Speed:	
Belt Length:		Belt Width :		Troughing Angle:	
Top Cover Condition:			Bottom Cover Condition:		
Splice:	Yes	No	Clip Joint:	Yes	No
Conveyor Running	Yes	No	Inspection Tags:	Yes	No
Edge Damage:	Yes	No			
Comments:					

### HEAD END / HEAD CHUTE

Chute Condition:	Head Pulley Lagging:
Snub Pulley Lagging:	Build up:
Belt Movement:	
Comments:	

### IDLER CHECK

Trough Idler Condition:	Return Idler Condition:
Troughing Frame Condition:	Return Frame Condition:
Comments:	

### PRIMARY SCRAPER

Position Correct:	Yes	No	Type of Primary Scraper installed:	
<small>(Contact of Scraper Blade must be between 10 to 30 degrees, under the pulley horizontal line.)</small>				
Mounts firmly mounted:	Yes	No	All bolts, nuts tightened:	Yes No
Adequate Tensioning:	Yes	No	All Caps, Denso Tape in place:	Yes No
Housekeeping:				
Chute Material build up:				
Blade Wear:	Low	Medium	High	Cleaning: Poor Fair Good
Comments:				

### SECONDARY SCRAPER #1

Type / Model of Secondary Scraper Installed:				
Positioning Correct:				
<small>(Scraper blade must preferably be a minimum 100mm from pulley tangent.)</small>				
All Caps, Denso Tape in Place:	Yes	No	Mounts firmly mounted:	Yes No
All Bolts & Nuts Tightened:	Yes	No	Adequate tension/adjustment:	Yes No
Angle Correct Set:	Yes	No	Carrier Frame cut to size	Yes No
<small>Angle of scraper must be 90 degrees to the conveyor belt, dependant on conditions.</small>				
Chute / Material build up:	Yes	No	Housekeeping:	
Blade wear:	Low	Medium	High	Cleaning: Poor Fair Good
Comments:				



DOC No	ISSUE No	REVISION	MARCH	PAGE
FS 023	02	02	2014	Page 1 of 3



## SECONDARY SCRAPER #2

Type / Model of Secondary Scraper Installed:																
Positioning Correct:																
Scraper blade must preferably be a minimum 100mm from pulley tangent.																
All Caps, Denso Tape in Place:			Yes		No		Mounts firmly mounted:			Yes		No				
All Bolts & Nuts Tightened:			Yes		No		Adequate tension/adjustment:			Yes		No				
Angle Correct Set:			Yes		No		Carrier Frame cut to size			Yes		No				
Angle of scraper must be 90 degrees to the conveyor belt, dependant on conditions.																
Chute / Material build up:			Yes		No		Housekeeping:									
Blade wear:			Low		Medium		High		Cleaning:		Poor		Fair		Good	
Comments:																

## TAKE UP PULLEYS / COUNTERWEIGHT / PLOUGH

Type / Model of Plough Installed:													
Are Flat Return Idlers Installed:		(In front)		Yes		No		(Behind)		Yes		No	
Any excessive belt movement:		Yes		No		Adequate space for material to fall off of conveyor belt				Yes		No	
Is the Plough firmly mounted:		Yes		No		Is the Safety Chain firmly mounted and correctly adjusted:				Yes		No	
Is the Plough Free moving:		Yes		No		Is the entire Blade / Nose Piece in contact with the conveyor belt:				Yes		No	
Housekeeping:													
Comments:													

## CONVEYOR BELT TRACKING / ALIGNMENT

Is the Belt Tracking centre:		Yes		No		Are there any Tracking Systems installed:			Troughing		Return		
Is there any visible damage to structure caused by poor belt tracking:						Yes			No				
Conveyor belt length:						Are the tracking systems correctly positioned:			Yes		No		
Are the tracking systems firmly mounted:				Yes		No		Are all bolts & nuts tightened:		Yes		No	
Are all Idlers in contact with the Belt - Adequate Tension on the system:						Yes		No		Housekeeping:			
Comments:													

## LOADING / TRANSFER CHUTE

Chute Condition:		Poor		Fair		Good		Material loading in centre of conveyor belt:					
Dead Boxes:		Yes		No		Deflector Plates:		Yes		No		Drop Heights:	
Tail Pulley Condition		Good		Fair		Poor							
Comments:													

## KEYSKIRTING®

Size of Keyskirt®:		1		2		3		4		Length of Keyskirt® Installed :			
Positioning of Keyskirt® :						Other Product used as Skirting		Yes		No		State	
Mounting Arrangement		Std.		Offset		Other							
All bolts & nuts securely fastened:				Yes		No		Housekeeping:					
Comments:													

### FEEDBOOTS

Type of Feedboot installed:	Universal	Combination	Is the system correctly positioned: (System to be positioned centrally to the load area.)				Yes	No
Drop Height:			Is the system securely mounted:				Yes	No
All Bolts & Nuts tightened:	Yes	No	Condition of Idlers:		Poor	Fair	Good	
Lead in and lead out Idlers in place:	Yes	No	Condition of UHMW Liners:		Low	Medium	High	
Housekeeping:								
Comments:								

### HI - IMPACT SYSTEM

Type of Hi - Impact system installed :								
Is the system correctly positioned:	Yes	No	Drop heights:					
System to be positioned centrally to the load area.								
Is the system securely mounted:	Yes	No	All bolts & nuts tightened:			Yes	No	
Are all Idlers in contact with the belt:	Yes	No	Idler condition:		Poor	Fair	Good	
BTA Condition:	Poor	Fair	Good	Are chains / D shackles in place & securely fastened:			Yes	No
All Hardware in Good Condition:	Yes	No	Housekeeping:					
Comments:								

### AIR CANNONS

Size of Air Cannon Installed:	5ltr	Quantity	10ltr	Quantity			
	25ltr	Quantity	50ltr	Quantity			
	100ltr	Quantity	200ltr	Quantity			
Is the Air Cannon securely fastened onto the structure:	Yes	No	Is an Air Lance installed:		Yes	No	
Size of the Air Lance:	Are the Air Cannons correctly positioned:			Yes	No		
Power supply:	Air supply:						
Operating system:	Single timer	PLC	Manual push button		Sequential		
All Bolts & Nuts securely tightened:	Yes	No	All components in good order:			Yes	No
Distance between Air Cannon & Solenoid Valve:	Any Air Leaks in the Pipe Work:			No			
Is a Water Trap Installed:	Yes	No	Is a Lubricator installed:			Yes	No
Distance from Air Cannon:	Distance from Air Cannon:						
Are the safety / warning signs in place and visible:	Yes	No	Housekeeping:				
Comments:							

### TAIL PULLEY / PLOUGH

Type / Model of Plough Installed:							
Are Flat Return Idlers installed:	(In front)	Yes	No	(Behind)	Yes	No	
Any excessive belt movement:	Yes	No	Adequate space for material to fall off of conveyor belt:			Yes	No
Is the Plough firmly mounted:	Yes	No	Is the Safety Chain firmly mounted and correctly adjusted:			Yes	No
Is the Plough free moving:	Yes	No	Is the entire Blade / Nose Piece in contact with the conveyor belt:			Yes	No
Housekeeping:							
Comments:							

## 10. Trouble Shooting

Problem	Possible Cause	Possible Solution
Poor cleaning performance	Scraper under-tensioned	Adjust to correct pressure - refer installation instructions
	Scraper over-tensioned	Adjust to correct pressure - refer installation instruction
	Scraper installed in wrong location	Verify dimension - refer installation drawing
	Scraper blade worn or damaged	Replace scraper blade
Rapid Blade Wear	Tension on scraper too high/low	Adjust to correct tension - refer installation instruction
	Scraper not located correctly	Check scraper location for correct dimensions
	Blade attack angle incorrect	Check scraper location for correct dimensions
	Material too abrasive for blade	Option: switch to alternate scraper tip grade (contact Brelko for available options)
	Mechanical splice damaging blade	Repair, skive or replace splice
Centre wear on blade (smile effect)	Blade smaller than material path	Add additional blade to match material path
	Tension on scraper too high/low	Adjust to correct pressure - refer installation instruction
Unusual wear or damage to blade	Mechanical splice damaging blade	Repair, skive or replace splice
	Belt damaged or ripped	Repair or replace belt
	Scraper not correctly located	Verify dimension - refer installation drawing
	Damage to pulley or pulley lagging	Repair or replace pulley
Vibration or noise	Scraper not located correctly	Verify dimension - refer installation drawing
	Blade attack angle incorrect	Verify dimension - refer installation drawing
	Scraper running on empty belt	Use a spray pole when the belt is empty
	Scraper tension too high/low	Adjust to correct tension or slight adjust to diminish
	Scraper locking bolts not secure	Check and tighten all bolts and nuts
	Scraper not square to head pulley	Verify dimension - refer installation drawing
	Material build-up in chute	Clean up build-up on scraper and in chute
Scraper being pushed away from pulley	Scraper tension not set correctly	Ensure correct tension/increase tension slightly
	Sticky material is overburdening scraper	Increase tension; add primary (head pulley) scraper
	Scraper not set up correctly	Confirm location dimensions are equal on both sides