

INSTALLATION, OPERATING & MAINTENANCE MANUAL

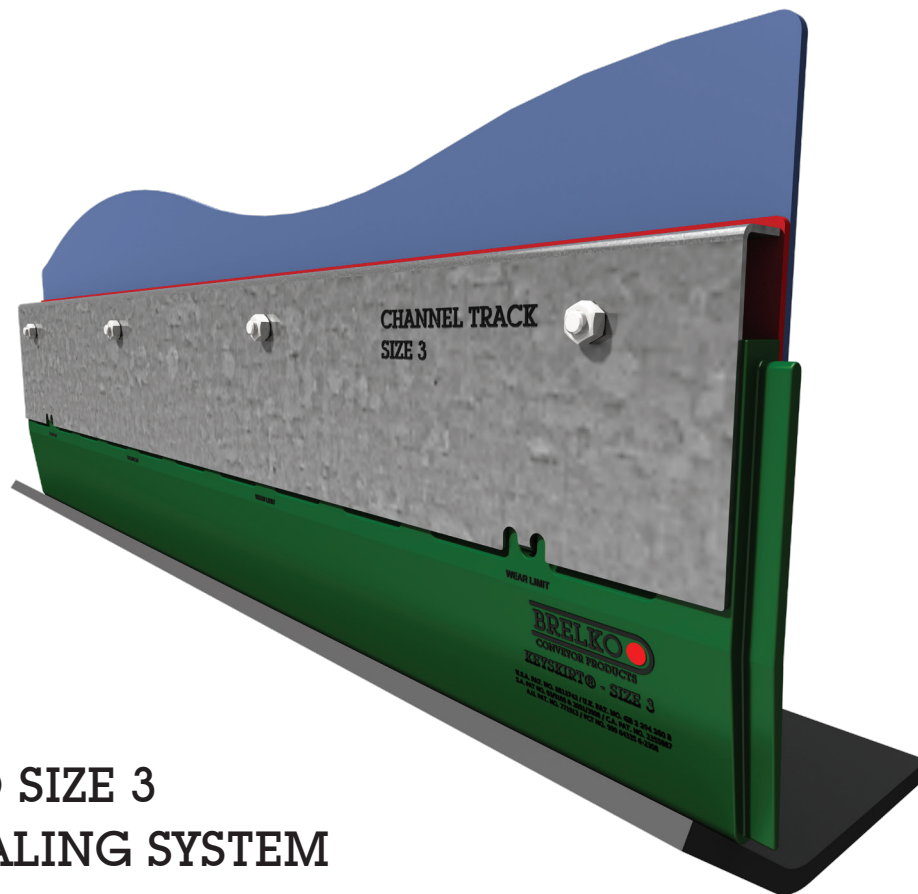

KEYSKIRT® SIZE 3 CHUTE SEALING SYSTEM

PATENTED

Model Number	:	
Purchase Date	:	
Purchased From	:	
Installation Date	:	

Model number information can be found on the Label found on the Keyskirt® wrapping. This information will be helpful for any future inquiries or questions about Keyskirt® replacement parts, specifications or troubleshooting.

Table of Contents

1.	Disclaimer	530
2.	Safety Note	530
3.	The following symbols may be used in this manual:	530
4.	General Information	530
4.1.	Application and Features (Standard System).	531
4.2.	Reference Drawing - KS3-018	532
5.	Handling	533
5.1.	Receiving the goods	533
5.2.	Work Safety	533
5.3.	Handling	534
5.4.	Storage	534
5.5.	Preparations for installing equipment	534
5.6.	Recommended Tools List	534
6.	Maintenance	535
6.1.	New Installation	535
6.2.	Routine Visual Inspection (every 2~4 weeks)	535
6.3.	Parts List and Assembly Instructions.	536
6.4.	Reference Drawing - KS3-019	537
6.5.	Installation Guide	538
6.6.	Reference Drawing - KS3-020	539
7.	Procedure for Replacing Keyskirt®	540
8.	Maintenance Log	541
9.	Conveyor Belt & Equipment Check List	542
10.	Trouble Shooting	545

1. Disclaimer

Brelko Conveyor Products (Pty) Ltd hereby disclaims any liability for: damage due to contamination of the material; user's failure to inspect, maintain and take reasonable care of the equipment; injuries or damage resulting from use or application of this product contrary to instructions and specifications contained herein. Brelko's liability shall be limited to repair or replacement of equipment shown to be defective.

2. Safety Note

Observe all safety rules given herein along with owner and Government standards and regulations. Know and understand lockout/tag-out procedures as defined by National Standards Institutes, National Standard for Personnel Protection - Lockout/Tag-out of Energy Sources - Minimum Safety Requirements and Occupational Health and Safety.

3. The following symbols may be used in this manual:



Danger: Immediate hazards that will result in severe personal injury or death.



Warning: Hazards or unsafe practices that could result in personal injury.



Caution: Hazards or unsafe practices that could result in product or property damages.

Important:

Important: Instructions that must be followed to ensure proper installation/operation of equipment.

Note:

Note: General statements to assist the reader.

4. General Information

Brelko Keyskirt® is designed to operate with minimum maintenance. However, to maintain superior performance some service is required. When the Keyskirt® is installed a regular maintenance program should be set up. This program will ensure that the Keyskirt® operates at optimal efficiency and problems can be identified and fixed before the Keyskirt® stops working. All safety procedures for inspection of equipment (stationary or operating) must be observed. Only visual observations can be made while the belt is running. Service tasks can be done only with the conveyor stopped and by observing the correct lockout/Tag-out procedures.

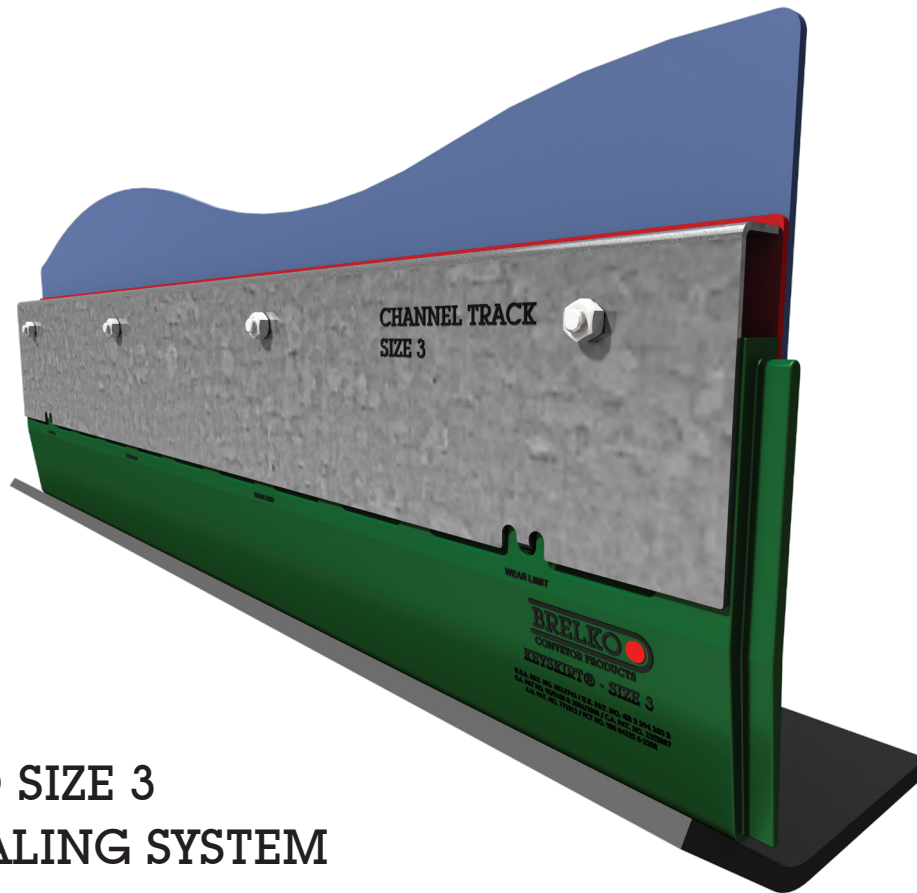

KEYSKIRT® SIZE 3 CHUTE SEALING SYSTEM

PATENTED

APPLICATIONS

- An effective chute sealing system designed to cope with spillage of large lump material where Size 1, 2 and 4 Keyskirts are liable to severe damage.
- Suitable for lump sizes over 150mm.

FEATURES

- Robust, cut and abrasion-resistant polyurethane sealing strip.
- Patented mounting system for easy strip replacement.
- Simple mounting allows easy and quick adjustment for sealing strip wear.
- Tongue and groove allows joining of more than one length.

POLYURETHANE GRADES

- Standard - 95SH(A)
- Fire Retardant - 95SH(A)

KEYSKIRT SIZE 3 - CHUTE SEALING SYSTEMS WITH POLYURETHANE SKIRTING

© 07-2015

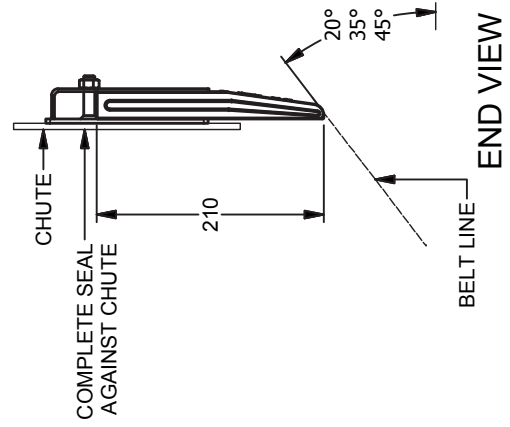
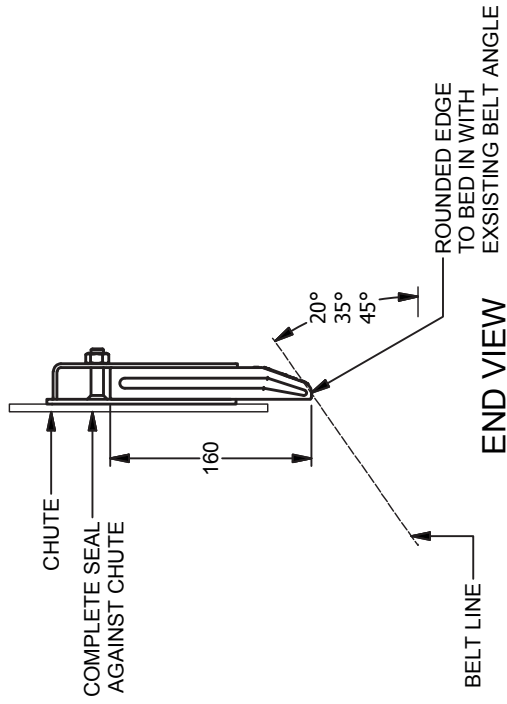
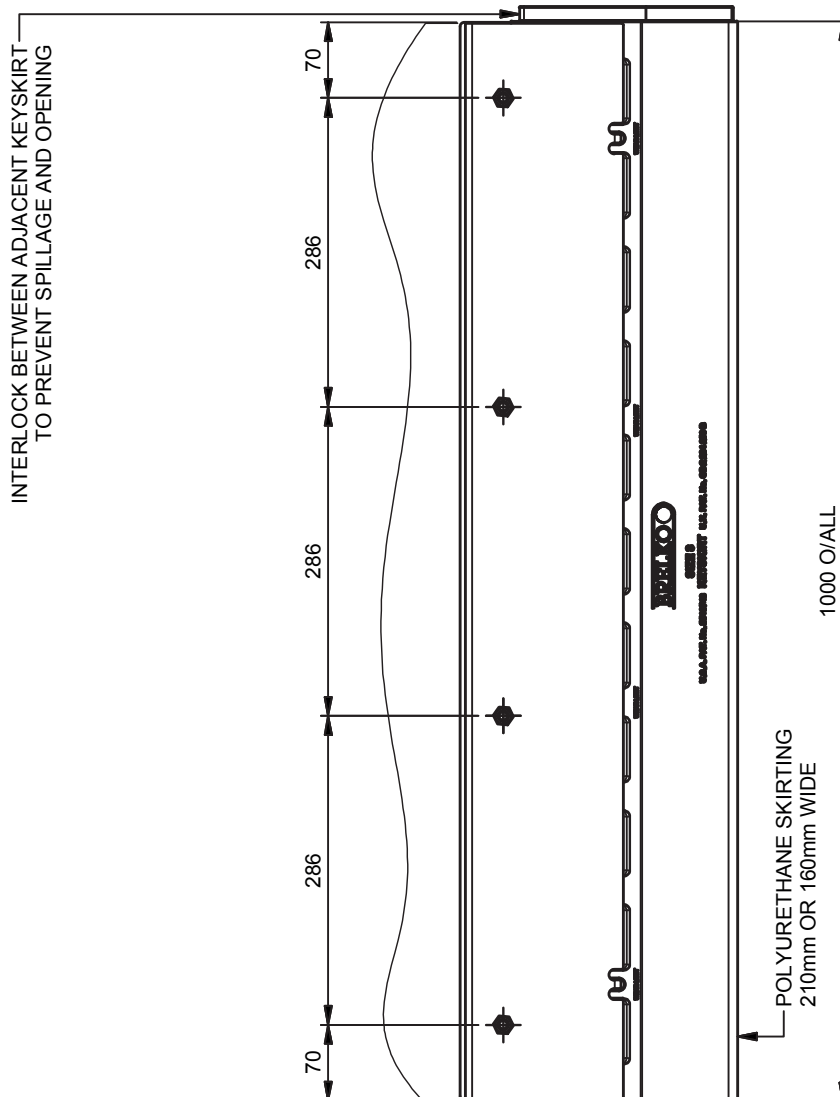

STANDARD CONSTRUCTION & FINISHES

NOTE: FEATURES & OPTIONS SHOWN:
PLEASE REFER TO DETAILED MANUAL FOR INSTALLATION INSTRUCTIONS, MAINTENANCE & SPARE PARTS

DRW: KS3 - 018
No.

REV. E

5. Handling

5.1. Receiving the goods

Check that the shipment contains all the products specified in the delivery note. If the goods do not match the delivery note, if the goods show any transportation damage, **list it on the freight bill**. Describe the damage and the number of wrong or faulty goods, **and contact your supplier immediately**.

Do not use defective parts under any circumstances. Claims must be made within 8 days from the arrival of goods. The factory does not cover expenses caused by exchange of product when installation was not carried out according to factory instructions.

5.2. Work Safety

Always use protective gloves and clothing. Always use a lifeline and soft-sole footwear when work will be carried out on raised platforms. Before you move any equipment, check that it is securely attached to the lifting equipment. Always observe local safety regulations.



Before removing/installing equipment, lock out/tag out energy source to conveyor, and/or conveyor accessories.

Turn off and lock out/tag out energy source according to local standards.

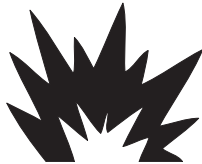

If equipment will be installed in an enclosed area, test gas level or duct content before using a cutting torch or welding. Using a cutting torch or welding in an area with gas or dust may cause an explosion.

If using a cutting torch or welding machine, test atmosphere for gas level or dust content.

5.3. Handling

When equipment is unloaded from the transportation vehicle onto customer's platform, place it on boards spaced max 1m apart at a minimum of 5cm from the ground.

5.4. Storage

Equipment can be stored unpacked or in transportation packaging. Equipment must not be stored on top of one another, protect the equipment by storing it in a cool dry area on a flat surface.

5.5. Preparations for installing equipment

Before installation, check all measurements and any of the other geometric design

5.6. Recommended Tools List

BRELKO KEYSKIRT®	
QTY	DESCRIPTION
2	EXTENSION CORD (30m MINIMUM)
1	PORT-A-PACK (OXY-ACETYLENE)
1	PRICKER
1	COMBINATION GAUGE (WITH SPIRIT LEVEL)
1	STRAIGHT EDGE (1M MINIMUM)
1	90° SET SQUARE
1	5M TAPE MEASURE
1	ADJUSTABLE SPANNERS
2	RINGSET SPANNERS - M13, 15, 16, 17, 18, 19, 24
1	STANLEY KNIFE
1	HARD FACE HAMMER - 4 PD
1	SOFT FACE HAMMER - 1 KG
1	NYLON ROPE (3 M)
2	G-CLAMPS - 6" - 8"
1	JIMMY LEVER
1	INVERTER (200 AMP)
1	WELDING HELMET
1 PAIR	WELDING SPATS
1	WELDING APRON
1	FIRE EXTINGUISHER (9 KG)
1	ANGLE GRINDER
1	BABY GRINDER
1	FLINT LIGHTER
1	FIRE BLANKET
1	CHALK LINE

All technical and dimensional information subject to change. All general Terms and Conditions of sale, including limitations of our liability, apply to all products and services sold.

6. Maintenance

Brelko Keyskirt® is designed to operate with minimum maintenance. However, to maintain superior performance some service is required. When the Keyskirt® is installed a regular maintenance program should be set up. This program will ensure that the Keyskirt® operates at optimal efficiency and problems can be identified and fixed before the Keyskirt® stops working. All safety procedures for inspection of equipment (stationary or operating) must be observed. Only visual observations can be made while the belt is running. Service tasks can be done only with the conveyor stopped and by observing the correct lockout/Tag-out procedures.

6.1. New Installation

After the new Brelko Keyskirt® has run for a few days a visual inspection should be made to ensure the Keyskirt® is performing properly.

6.2. Routine Visual Inspection (every 2~4 weeks)

A visual inspection of the Keyskirt® and the belt can determine:

- Check Keyskirt® for wear;
- Make sure that the clamps are tight;
- Make sure that the Keyskirt® is resting on the conveyor belt.

If any of the above conditions exist, a determination should be made on when the conveyor can be stopped for Keyskirt® Maintenance. When maintenance tasks are completed, test run the conveyor to ensure the Keyskirt® is performing properly.

PARTS LIST - REF. DRW. No.: KS3-019

ITEM No.	DESCRIPTION	SIZE	LENGHT (m)	BELT WIDTH (mm)	CODE
A	Keyskirt® Standard Polyurethane - 210mm	Size 3	1	From 600mm upwards	9-2.9-1
	Keyskirt® Standard Polyurethane - 160mm	Size 3	1	From 600mm upwards	9-2.9-2
	Keyskirt® F.R.A.S.O.R. Polyurethane - 210mm	Size 3	1	From 600mm upwards	9-91-1
	Keyskirt® F.R.A.S.O.R. Polyurethane - 160mm	Size 3	1	From 600mm upwards	9-2.91-2
B	Keyskirt® channel track – C/W backing strip, nuts & washers - 210mm	SIZE 3	1	From 600mm upwards	9-1.2.3
	Keyskirt® channel track – C/W backing strip, nuts & washers - 160mm	SIZE 3	1	From 600mm upwards	9-1.2.31

NOTE! Always quote belt width.

ASSEMBLY INSTRUCTIONS

1. Check that the correct quantities and size of components have been supplied as ordered by referring to parts list and DRW. No.: KS3-019.
2. Place polyurethane skirt (1) on backing plate (3).
3. Fit clamp plate (2) over skirt (1) and the studs of backing plate (3).
4. Ensure that the two guide pins on the clamp plate (2) engage in the slots of the skirt (1).
5. Tighten clamp nuts (4).

KEYSKIRT SIZE 3 - CHUTE SEALING SYSTEM WITH POLYURETHANE SKIRTING

© 07-2015

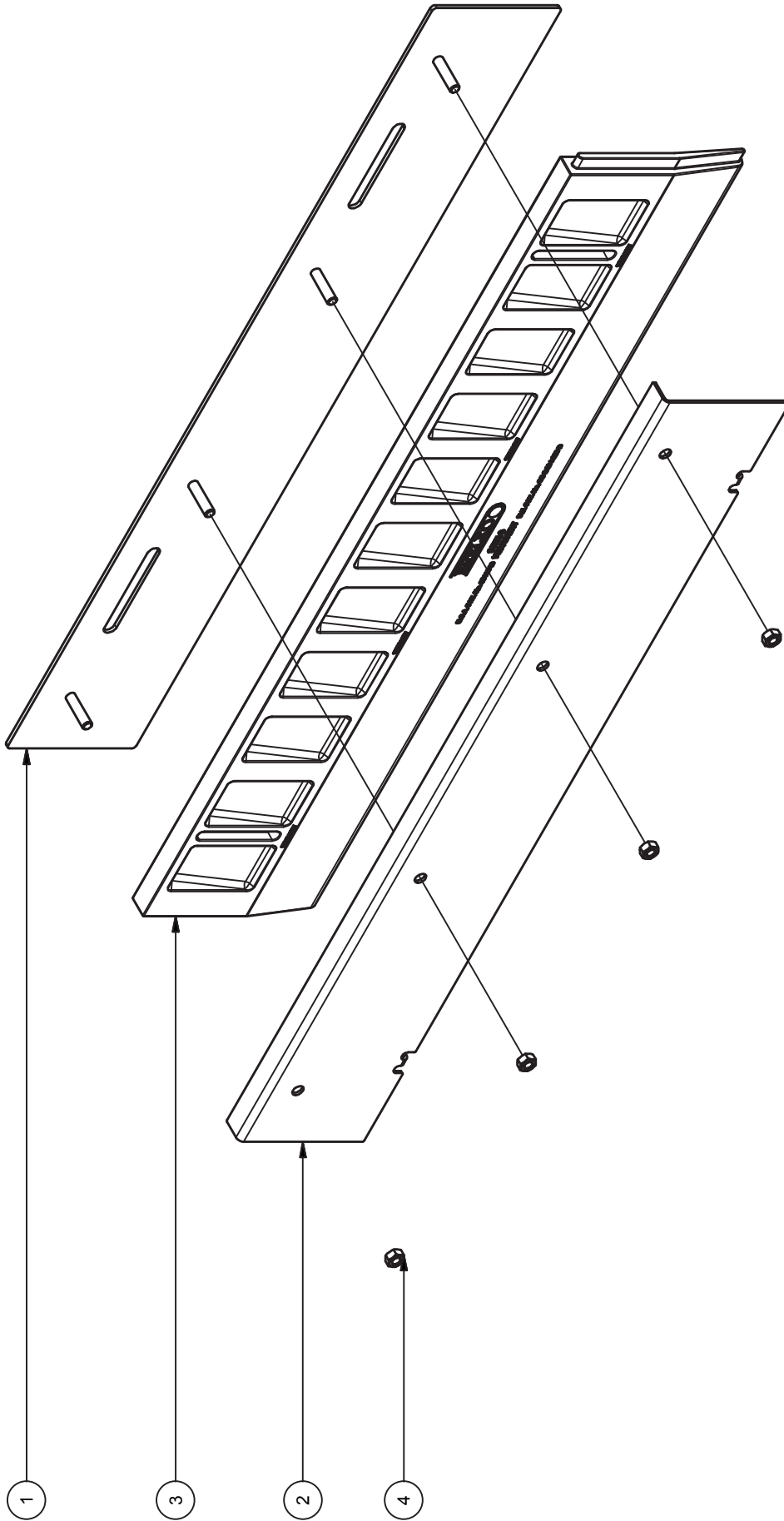

LEGEND	
DESCRIPTION	COMPONENT I.D
BACKING STRIP C/W STUDS	1
CHANNEL TRACK	2
KEYSKIRT SIZE 3 (PLEASE SPECIFY SIZE)	3
M12 NUTS	4

PARTS LIST: 210mm WIDE (STD) OR 160mm (ON REQUEST).

DRW. KS3 - 019
No.

REV. E

INSTALLATION GUIDE - REF. DRW. No.: KS3-020

1. Size -3 Keyskirt® is used where the particle sizes and drop height could damage Size -1, -2 and -4 Keyskirt®.
2. Size -3 Keyskirt® can also be used as a side wall on a flat belt, where limited spillage can be tolerated.
3. Position the backing plates (1000mm long) on the chute sides as indicated on DRW. No.: KS-3-020.
4. Weld in position.
5. Fit Keyskirt® and outer clamp plate. Ensure that the two vertical grooves in the Keyskirt® engage with the pins in the backing plate.
6. Rest the Keyskirt® on the conveyor belt and finger tighten the clamp plate nuts.
7. Ensure adjacent lengths of Keyskirt® engage at their ends.
8. Finally adjust the Keyskirt® to lightly touch the conveyor and tighten the clamp plate nuts.
9. Check running of conveyor to ensure there are no high spots or thicker sections which could foul the Keyskirt®.

KEYSKIRT SIZE 3 - CHUTE SEALING SYSTEMS WITH POLYURETHANE SKIRTING

© 07-2015

CHANNEL TRACK

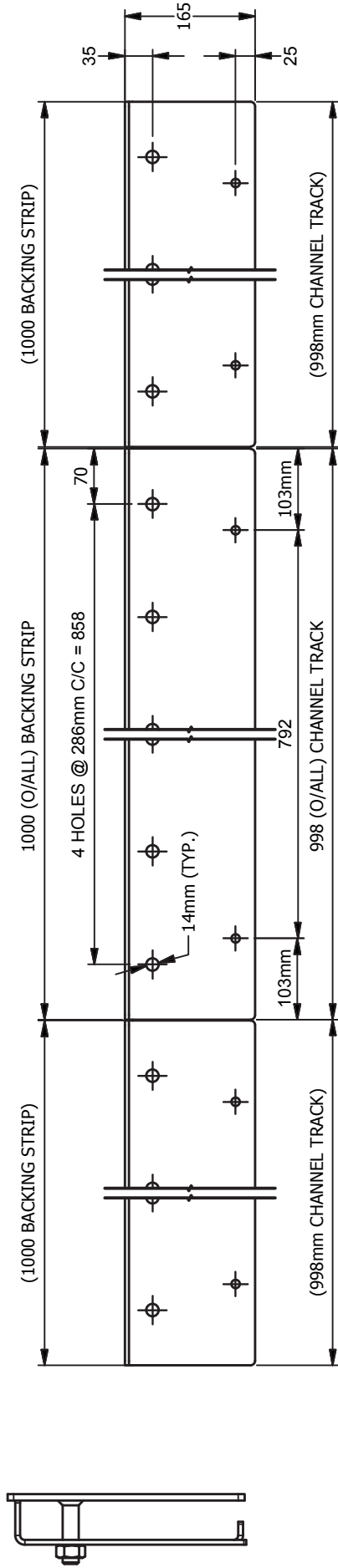

END VIEW

SIDE VIEW

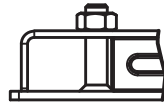

OPTIONAL MOUNTING DIRECTLY TO CHUTE

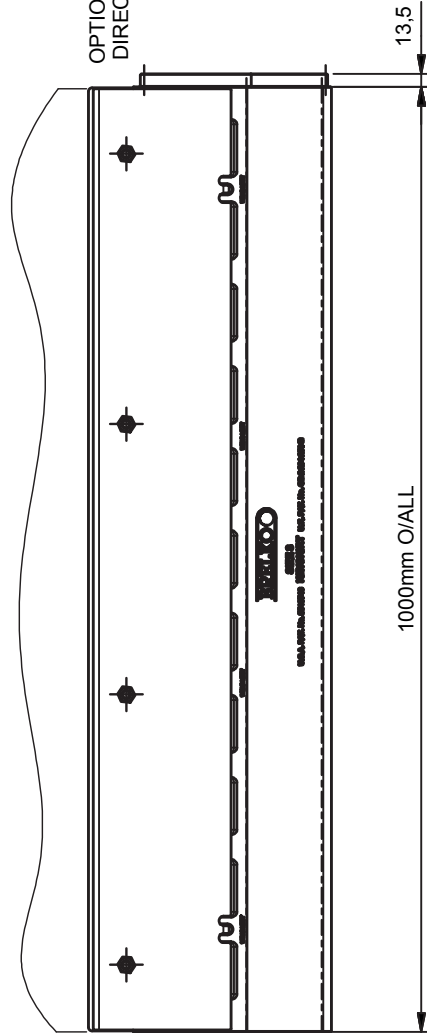

SIDE VIEW

END VIEW

END VIEW

STANDARD CONSTRUCTION & FINISHES

INSTALLATION DETAIL: STANDARD MOUNT

DRW. No. KS3 - 020

REV. E

7. Procedure for Replacing Keyskirt®

Repair/replace Keyskirt® components when, general maintenance tasks are performed, damage due to accelerated wear, Keyskirt® damage due to clip joints, overloading etc.

7.1. Request permit to work from an authorised person, who will isolate and lock out the belt.

7.2. Loosen the locknuts and then remove the Keyskirt®.

7.3. Keyskirt® replacement:

Refer to Brelko installation instructions for Keyskirt® model in use.

If Keyskirt® damaged occur follow the steps below to replace individual or all of the Keyskirt:

7.3.1. Ensure that the chute / belt clearance is sufficient as shown on the relevant drawings.

7.3.2. Mark out and weld the channel backing strips to the chute sides as shown on the drawing.

Note: If no backing strip is used refer to technical bulletin KEY1 – 01/99, available on request.

7.3.3. Where there is a long run of skirting check that the drag is not excessive. (Refer to data – see DRW. No.: KS1-007). It may be necessary to adjust the mounting angle of the Keyskirt® to reduce drag. Brelko “KeyKlamps” are recommended for quick replacement of Keyskirt®.

7.3.4. Keyskirt® is supplied in 10m lengths. They can be cut to size and also joined using suitable cold splicing compounds. (See technical bulletin KEY2 - 01/99, available on request).

7.3.5. Keyskirt® should be replaced when the ribs are worn away.

7.3.6. No running adjustments are required.

7.3.7. To further enhance the sealing benefit of Keyskirt® we recommend the installation of Brelko Feedboots at the various conveyor load points.

7.3.8. Ensure that the conveyor belt has been properly aligned and is tracking true so as to avoid Keyskirt® slipping off the belt edge.

7.3.9. Clear up any loose items which resulted from your work.

CONVEYOR BELT & EQUIPMENT CHECK LIST

CUSTOMER DETAILS

Customer Name:		Contact Number:	
Attention:		Date of Inspection	
Inspected By		Brelko Representative	

CONVEYOR DIMENSIONS

Belt Number:		Material Carried:		Belt Speed:		
Belt Length:		Belt Width :		Troughing Angle:		
Top Cover Condition:				Bottom Cover Condition:		
Splice:	Yes	No	Clip Joint:	Yes	No	
Conveyor Running	Yes	No	Inspection Tags:	Yes	No	
Edge Damage:	Yes	No		Cover Strip:	Yes	No
Comments:						

HEAD END / HEAD CHUTE

Chute Condition:		Head Pulley Lagging:	
Snub Pulley Lagging:		Build up:	
Belt Movement:			
Comments:			

IDLER CHECK

Trough Idler Condition:		Return Idler Condition:	
Troughing Frame Condition:		Return Frame Condition:	
Comments:			

PRIMARY SCRAPER

Position Correct:	Yes	No	Type of Primary Scraper installed:				
(Contact of Scraper Blade must be between 10 to 30 degrees, under the pulley horizontal line.)							
Mounts firmly mounted:	Yes	No	All bolts, nuts tightened:	Yes	No		
Adequate Tensioning:	Yes	No	All Caps, Denso Tape in place:	Yes	No		
Housekeeping:							
Chute Material build up:							
Blade Wear:	Low	Medium	High	Cleaning:	Poor	Fair	Good
Comments:							

SECONDARY SCRAPER #1

Type / Model of Secondary Scraper Installed:							
Positioning Correct:							
(Scraper blade must preferably be a minimum 100mm from pulley tangent.)							
All Caps, Denso Tape in Place:	Yes	No	Mounts firmly mounted:	Yes	No		
All Bolts & Nuts Tightened:	Yes	No	Adequate tension/adjustment:	Yes	No		
Angle Correct Set:	Yes	No	Carrier Frame cut to size	Yes	No		
Angle of scraper must be 90 degrees to the conveyor belt, dependant on conditions.							
Chute / Material build up:	Yes	No	Housekeeping:				
Blade wear:	Low	Medium	High	Cleaning:	Poor	Fair	Good
Comments:							

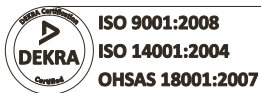

DOC No	ISSUE No	REVISION	MARCH	PAGE
FS 023	02	02	2014	Page 1 of 3



SECONDARY SCRAPER #2

Type / Model of Secondary Scraper Installed:																
Positioning Correct:																
Scraper blade must preferably be a minimum 100mm from pulley tangent.																
All Caps, Denso Tape in Place:			Yes		No		Mounts firmly mounted:			Yes		No				
All Bolts & Nuts Tightened:			Yes		No		Adequate tension/adjustment:			Yes		No				
Angle Correct Set:			Yes		No		Carrier Frame cut to size			Yes		No				
Angle of scraper must be 90 degrees to the conveyor belt, dependant on conditions.																
Chute / Material build up:			Yes		No		Housekeeping:									
Blade wear:			Low		Medium		High		Cleaning:		Poor		Fair		Good	
Comments:																

TAKE UP PULLEYS / COUNTERWEIGHT / PLOUGH

Type / Model of Plough Installed:													
Are Flat Return Idlers Installed:		(In front)		Yes		No		(Behind)		Yes		No	
Any excessive belt movement:		Yes		No		Adequate space for material to fall off of conveyor belt				Yes		No	
Is the Plough firmly mounted:		Yes		No		Is the Safety Chain firmly mounted and correctly adjusted:				Yes		No	
Is the Plough Free moving:		Yes		No		Is the entire Blade / Nose Piece in contact with the conveyor belt:				Yes		No	
Housekeeping:													
Comments:													

CONVEYOR BELT TRACKING / ALIGNMENT

Is the Belt Tracking centre:		Yes		No		Are there any Tracking Systems installed:			Troughing		Return		
Is there any visible damage to structure caused by poor belt tracking:						Yes			No				
Conveyor belt length:						Are the tracking systems correctly positioned:			Yes		No		
Are the tracking systems firmly mounted:				Yes		No		Are all bolts & nuts tightened:		Yes		No	
Are all Idlers in contact with the Belt - Adequate Tension on the system:						Yes		No		Housekeeping:			
Comments:													

LOADING / TRANSFER CHUTE

Chute Condition:		Poor		Fair		Good		Material loading in centre of conveyor belt:					
Dead Boxes:		Yes		No		Deflector Plates:		Yes		No		Drop Heights:	
Tail Pulley Condition		Good		Fair		Poor							
Comments:													

KEYSKIRTING®

Size of Keyskirt®:		1		2		3		4		Length of Keyskirt® Installed :			
Positioning of Keyskirt® :						Other Product used as Skirting		Yes		No		State	
Mounting Arrangement		Std.		Offset		Other							
All bolts & nuts securely fastened:				Yes		No		Housekeeping:					
Comments:													

FEEDBOOTS

Type of Feedboot installed:	Universal		Combination		Is the system correctly positioned: (System to be positioned centrally to the load area.)	Yes	No	
Drop Height:					Is the system securely mounted:	Yes	No	
All Bolts & Nuts tightened:	Yes		No		Condition of Idlers:	Poor	Fair	Good
Lead in and lead out Idlers in place:	Yes		No		Condition of UHMW Liners:	Low	Medium	High
Housekeeping:								
Comments:								

HI - IMPACT SYSTEM

Type of Hi - Impact system installed :										
Is the system correctly positioned:	Yes		No		Drop heights:					
System to be positioned centrally to the load area.										
Is the system securely mounted:	Yes		No		All bolts & nuts tightened:	Yes		No		
Are all Idlers in contact with the belt:	Yes		No		Idler condition:	Poor	Fair	Good		
BTA Condition:	Poor		Fair	Good	Are chains / D shackles in place & securely fastened:	Yes		No		
All Hardware in Good Condition:	Yes		No		Housekeeping:					
Comments:										

AIR CANNONS

Size of Air Cannon Installed:	5ltr		Quantity		10ltr		Quantity		
	25ltr		Quantity		50ltr		Quantity		
	100ltr		Quantity		200ltr		Quantity		
Is the Air Cannon securely fastened onto the structure:	Yes		No		Is an Air Lance installed:	Yes		No	
Size of the Air Lance:					Are the Air Cannons correctly positioned:	Yes		No	
Power supply:					Air supply:				
Operating system:	Single timer		PLC		Manual push button		Sequential		
All Bolts & Nuts securely tightened:	Yes		No		All components in good order:	Yes		No	
Distance between Air Cannon & Solenoid Valve:					Any Air Leaks in the Pipe Work:	No			
Is a Water Trap Installed:	Yes		No		Is a Lubricator installed:	Yes		No	
Distance from Air Cannon:					Distance from Air Cannon:				
Are the safety / warning signs in place and visible:	Yes		No		Housekeeping:				
Comments:									

TAIL PULLEY / PLOUGH

Type / Model of Plough Installed:									
Are Flat Return Idlers installed:	(In front)	Yes		No		(Behind)	Yes		No
Any excessive belt movement:	Yes		No		Adequate space for material to fall off of conveyor belt:	Yes		No	
Is the Plough firmly mounted:	Yes		No		Is the Safety Chain firmly mounted and correctly adjusted:	Yes		No	
Is the Plough free moving:	Yes		No		Is the entire Blade / Nose Piece in contact with the conveyor belt:	Yes		No	
Housekeeping:									
Comments:									

10. Trouble Shooting

Problem	Possible Cause	Possible Solution
Keyskirt® damaged	Belt Drift	Fit Belt Tracking Systems, preferably fit Brelko Belt Tracking Systems